

## Technische Dokumentation Technical Documentation



### **TUFLIN® Fully Lined Plug Valves Two-way & Multiport Configurations**

## Design Features & Benefits

TUFLIN® fully lined plug valves are cavity-free. Due to the special body design, the liner is firmly locked. Plug coating is extended over the shaft sealing. Liners manufactured by TUFLIN® are non-porous and 100% dielectrically spark tested.

For safety reasons, liner wall thickness are oversized.

Plastic liner materials are selected according to requirements. TUFLIN® plug valves are used for applications where other materials have insufficient chemical resistance or are not economical.

TUFLIN® plastic lined plug valves fully meet the leakage requirements of DIN 3230 Standard, page 3, leak rate 1.

## Scope of Supply

### Materials:

Body: EN-JS1049 (GGG 40.3, 0.7043) or A352-LCB (DN 32 only in 0.7043)  
Body lining: PFA  
Plug: Up to DN 32 NPS 1 ¼ plug core made form steel (1.0570)  
From DN 40 NPS 1 ½ plug core made from  
EN-JS1049 (GGG 40.3, 0.7043)  
or steel (1.0570/ 1.0727)  
PFA lining

Jacket: 1.0038

### Face-to-face dimension acc. to EN 558-1 / EN 558-2

Standard design for manual operation:

up to DN 100 / NPS 4: with handle  
from DN 150 / NPS 6: with worm gear

For pneumatic and electric actuators please refer to technical data sheet tdb\_xrp.

### Temperature range:

233 K up to 473 K (-40°C up to 200°C) for PFA

Suitable for vacuum service: (1.33 mbar / hPa)

Operating pressure max. 10 bar

### Available sizes and flange dimensions:

PN 10 DN 15 - 300  
PN 16 DN 15 - 300  
CL 150 NPS ½ - 12  
JIS 10 k DN 15 - 300

### Paint:

- 1) Standard paint: 1 compound Urethane-Alkyde green RAL 6011  
Application: Primer for further paints on 1- or 2 compound level
- 2) On request: Epoxy primer and coating based on AY-PUR (Acryle-Polyuretane) orange RAL2009  
Application: Industrial and Sea water environment. Further paintings on request.

**Orders without specifications will be delivered with standard paint.**

## Type test approval VdTÜV-M229 for plants subject to inspection:

Rule	Dampfkv	DruckbehV	Gas HL-VO	VbF
Code	TRD	TRB/TRR	TRGL/DVGW	TRbF

### Optionen:

- Jacketed versions
- Valves cleaned for chlorine-application
- Valves cleaned for oxygen-application

### Part description

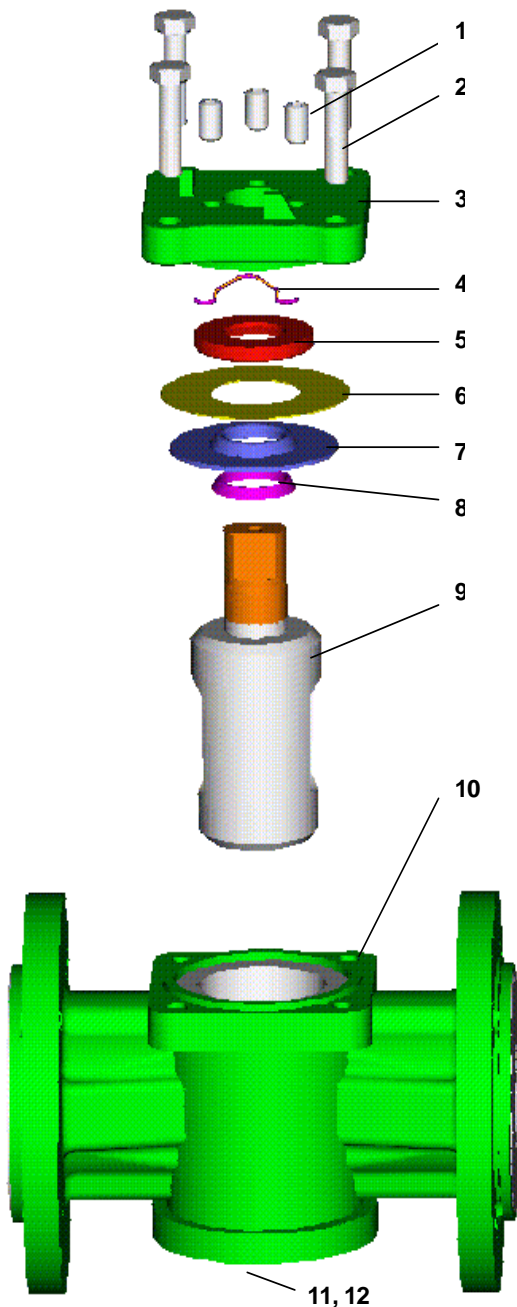

### Partlist

Item	Qty.	Description	Material
1	3	Set Screws	1.4301
2	4	Cover Screws	1.4408
3	1	Cover	EN-JS 1049 (GGG 40.3)
4	1	Anti-Static Device	1.4571
5	1	Trust Collar	1.4401
6	1	Metal Diaphragm	1.4401
7	1	Formed Diaphragm	Teflon®
8	1	Wedge Ring	Teflon®
9	1	Plug	EN-JS 1049 (GGG 40.3); PFA coated
10	1	Body	EN-JS 1049 (GGG 40.3), PFA
11	1	Set screw	1.4408
12	1	Lock Nut	1.4408

## Flow Coefficient, $K_v$ in $m^3/h$ , $C_v=1,156 K_v$

DNN PS	15 ½	20 ¾	25 1	32 1 ¼	40 1 ½	50 2	65 2 ½	80 3	100 4	150 6	200 8	250 10	300 12
<b>Cv</b>	12.6	35	57	57	213	295	630	670	1400	2125	*	*	*
<b>Kvs</b>	10.9	30	49	49	184	255	545	580	1211	1838	*	*	*
<b>Kva</b>	8	8	30	30	63	125	125	220	400	800	1195	1795	2650

\* on request

## Valve coefficients for process control: DN 15 – 300 / NPS ½ - 12

Angel of aperture	9°	18°	27°	36°	45°	54°	63°	72°	81°	90°
<b>Rated travel</b>	<b>0.10</b>	<b>0.20</b>	<b>0.30</b>	<b>0.40</b>	<b>0.50</b>	<b>0.60</b>	<b>0.70</b>	<b>0.80</b>	<b>0.90</b>	<b>1.00</b>
Recovery factor $F_L$	-	0.89	0.88	0.87	0.85	0.82	0.78	0.72	0.68	0.64
Factor $F_L^2$	-	0.79	0.77	0.76	0.72	0.67	0.61	0.52	0.46	0.41
Valve Characteristic $z_y$	-	0.50	0.49	0.48	0.47	0.44	0.41	0.36	0.33	0.30
Pressure differential ratio $\kappa_T$	-	0.67	0.65	0.64	0.61	0.56	0.51	0.44	0.39	0.34
Valve style modifier $F_d$	The calculation value is a function of the required flow coefficient									

## Pressure- Temperature- Rating for body and liner

Temperature in °C	- 40	- 20	0	20	40	60	80	100	120	140	160	180	200
<b>Operating pressure PFA</b>	0	5.8	10	10	10	10	10	10	10	10	9.5	5	

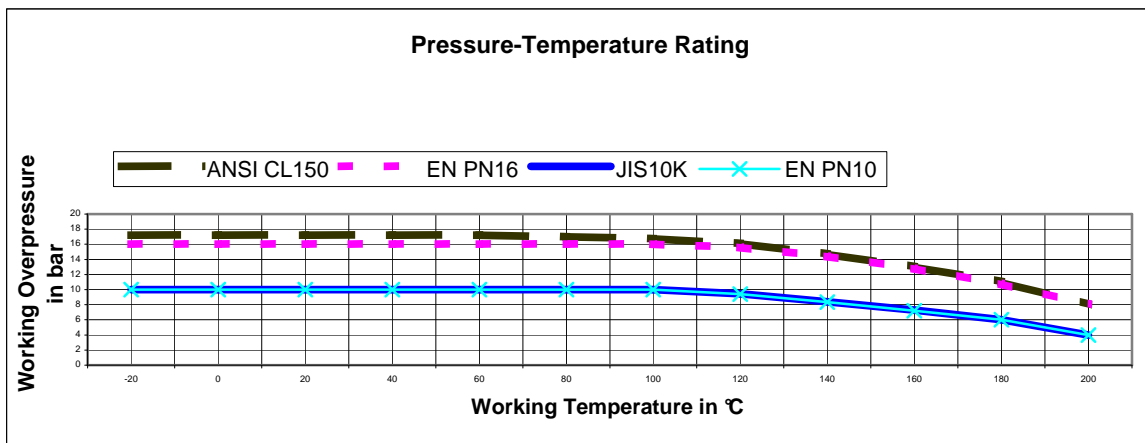

Maximum allowable operating temperature of lining: PFA: ≤ 200°C

## TUFLIN® Fully Lined Flanged Two Way Valves

**Type 121** flanges as per DIN PN 10-16  
**Type 021** flanges as per ANSI Class 150  
**Type 8121, 8021, 821** flanges drilled to JIS 10 K  
 Other pressure classes on request  
 Exact types per size see dimension table below.

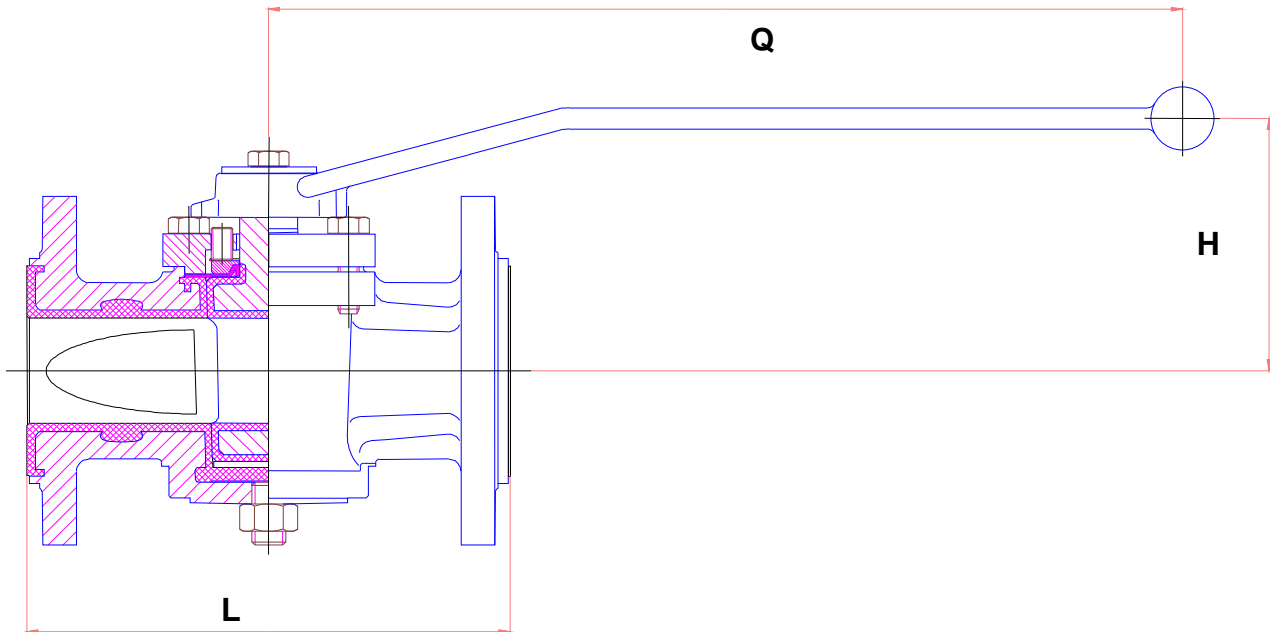

### Dimensions with wrench in mm

DN DIN	NPS ANSI	DIN	L ANSI	H	Q	Approx. weight / kg		Break-away torque [Nm]
						DIN	ANSI	
15	½	130	*	94	260	3.4	3.4	65
20	¾	150	*	94	260	4.0	4.0	65
25	1	160	127	94	260	5.0	3.2	65
32	1¼	180	*	94	260	7.0	7.0	65
40	1½	200	165	106	362	7.8	6.0	100
50	2	230	178	118	435	11.4	9.5	160
65	2½	290	*	118	435	16.0	16.0	160
80	3	310	203	132	435	17.4	14.5	210
100	4	350	229	149	600	29.4	22.5	300

## Fully Lined Two Way Valves, Dimensions with gear

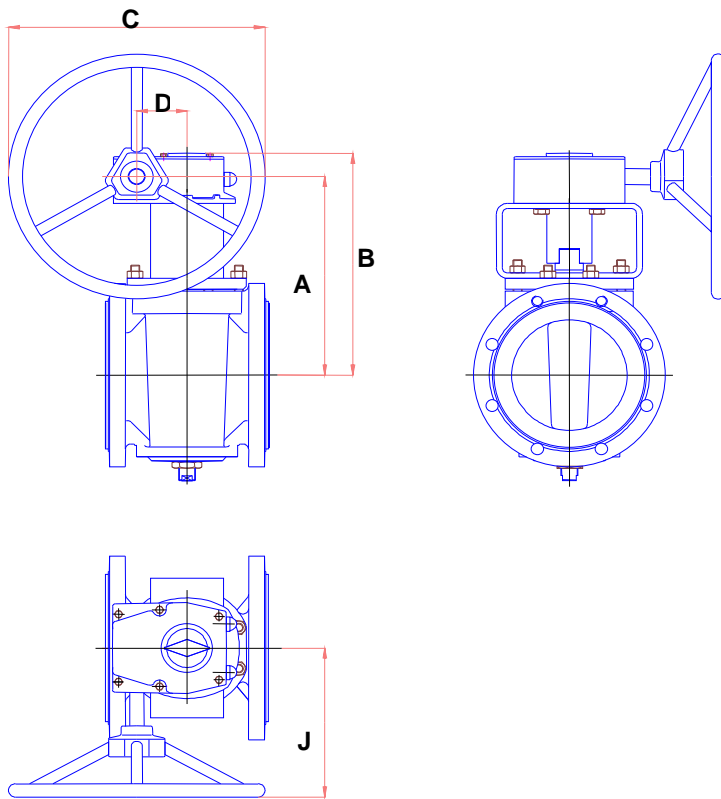

### Dimensions with gear in mm

DN	NPS	L		A	B	C	D	J	Approx. weight / kg		Break-away torque [Nm]
		DIN	ANSI						DIN	ANSI	
100	4	350	229	233	265	250	52	184	43.0	36.0	300
150	6	**	267	304	343	300	66.7	223		53.4	650
200	8	**	292	380.5	424	457	89.5	279		88.0	1200
250	10	**	330	408.5	464	610	123	366		150.0	1800

DN 300 / NPS 12 on request

Face-to-face dimensions and flanges

- \*\* Type 121 Face-to-face and flanges ANSI – drilled as per DIN
  - \* Type 0121 Face-to-face and flanges DIN – drilled as per ANSI Class 150
  - Type 8121 Face-to-face and flanges DIN – drilled as per JIS 10 K
  - Type 8021 Face-to-face and flanges ANSI – drilled as per JIS 10 K
  - Type 821 Face-to-face and flanges JIS – drilled as per JIS 10 K
- only available in material EN-JS 1049 (GGG 40.3, 0.7043)  
DN 25 (F/F = 127) und DN 100 (F/F = 229)

Other pressure classes on request

## TUFLIN® Fully Lined Flanged Three Way Valves

Type 131: DIN PN 10-16  
 Type 0131: ANSI Class 150  
 Type 8131: JIS 10 K

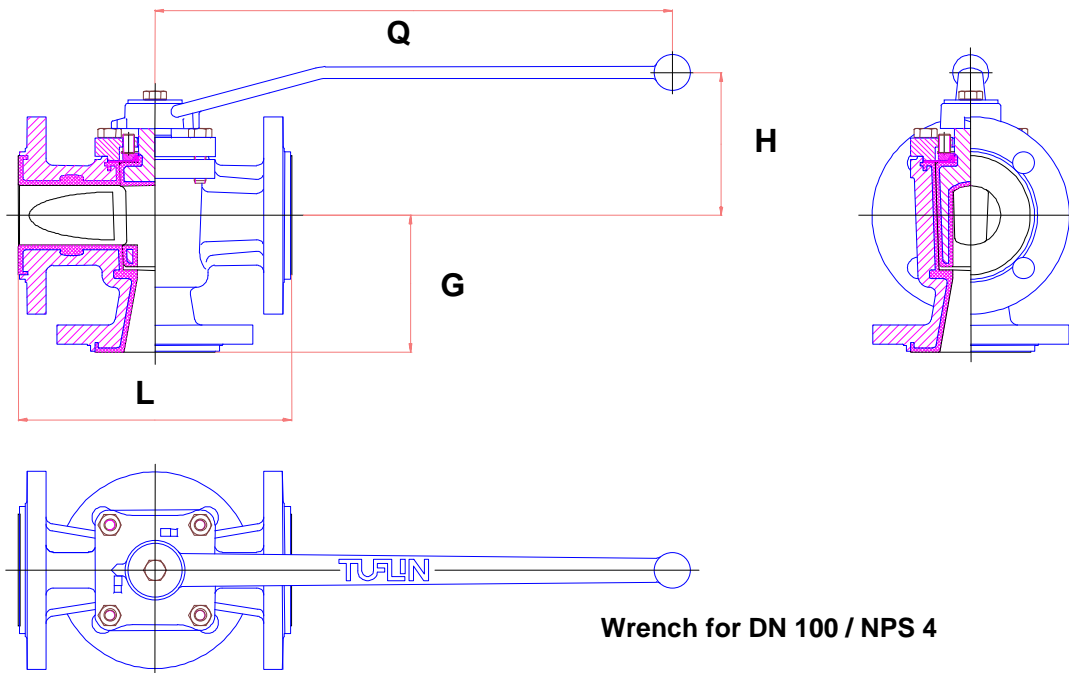

### Dimensions in mm

DN	NPS	DN	L			G	H	Q	Approx. weight	Break-away torque
131	0131*	8131*	131	0131	8131				[kg]	[Nm]
15	½	15	130	130	130	80	94	260	3.5	65
20	¾	20	150	150	150	75	94	260	4.5	65
25	1	25	160	160	160	80	96	260	6.0	65
40	1½	40	200	200	200	100	106	362	9.0	100
50	2	50	230	230	230	115	118	435	14.0	160
65	2½	65	290	290	290	145	118	435	19.0	160
80	3	80	310	310	310	155	132	435	21.5	210
100	4	100	350	350	350	175	149	600	32.0	300

\* DIN flanges drilled to ANSI Class 150 / JIS 10 kg

Available port arrangements: A-Plug, AX-Plug and C-Plug

Please advise required port arrangement when ordering.

Other material, pressure classes and port arrangements upon request.

## TUFLIN® Plug Port Arrangements Three Way Valves, Type 131 / 0131 / 8131

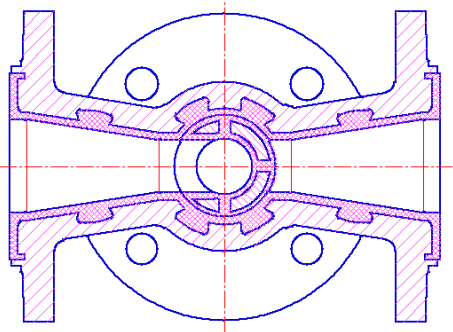

A-Plug

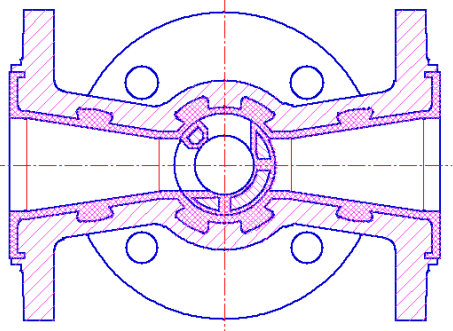

AX-Plug

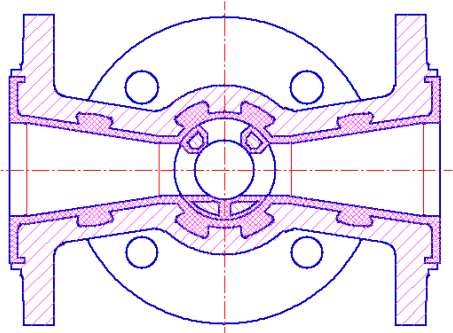

C-Plug

**Please advise required port arrangement when ordering.**



## TUFLIN® Fully Lined Flanged Three Way Valves

Type 771: DIN PN 10-16  
 Type 0771: ANSI Class 150  
 Type 8771: JIS 10 K

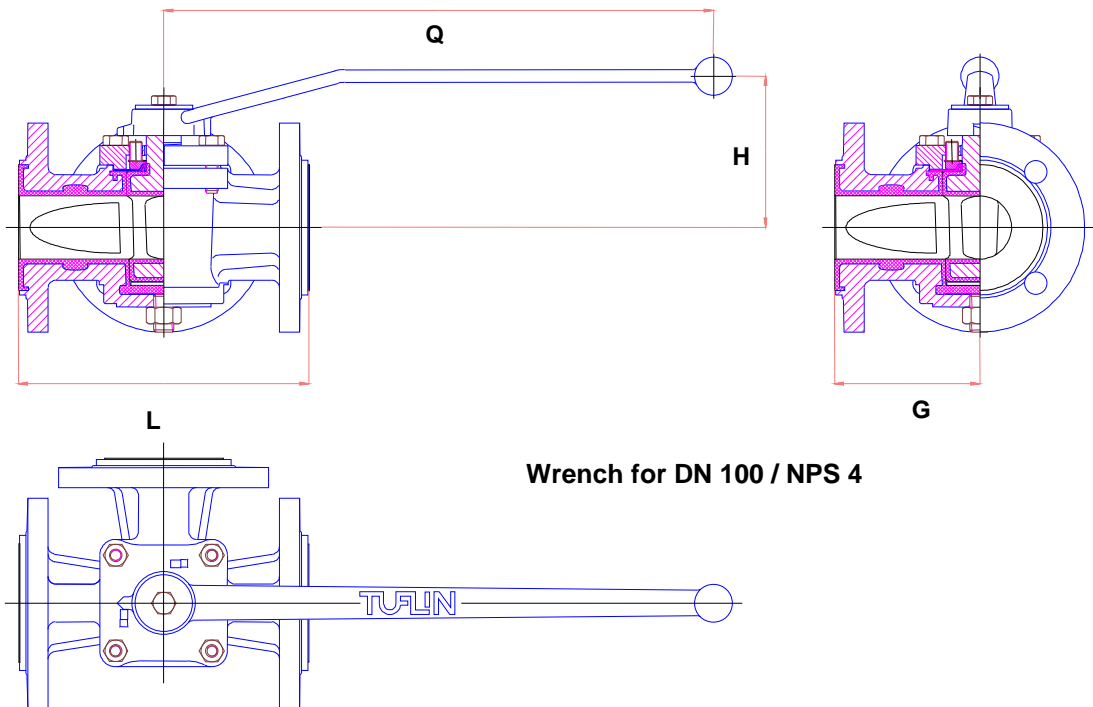

### Dimensions with wrench in mm

DN	NPS	DN	L			G	Q	H	Approx. weight	Break-away torque
771	0771*	8771*	771	0771	8771				[kg]	[Nm]
25	1	25	160	160	160	80	96	260	5.0	65
40	1½	40	200	200	200	100	106	362	10.0	100
50	2	50	230	230	230	115	118	435	14.0	160
65	2½	65	290	290	290	145	118	435	19.0	160
80	3	80	310	310	310	155	132	435	21.0	210
100	4	100	350	350	350	175	149	600	31.0	300

### Material

Body: EN-JS1049 (GGG 40.3, 0.7043); except DN 15, 20, 32, 65 and 100 or A352-LCB  
 Body lining: PFA  
 Plug: Plug core steel (1.0570) 1.0727  
 PFA lining by choice

Available port arrangements: L-Plug and T-Plug  
 Please advise necessary port arrangement when ordering.

Other material, pressure classes and port arrangements upon request.  
 Subject to technical modifications

## TUFLIN® Three Way Valves, Type 771 / 0771 / 8771, Dimensions with gear

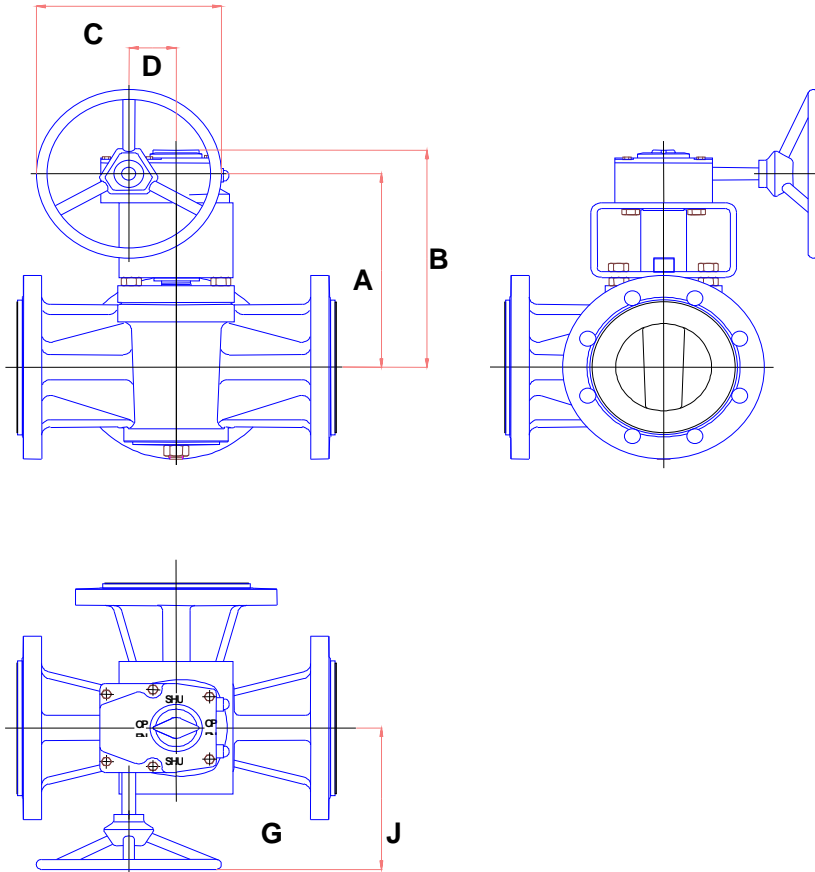

### Dimensions with wrench in mm

DN	NPS	DN	L			G	A	B	C	D	J	Approx. weight [kg]	Break torque [Nm]
			771	0771	8771								
100	4	100	350	350	350	175	255	296	356	67	207	42.0	300
150	6	150	267	267	267	200	291	332	356	67	207	68.0	650

\* DIN flanges drilled to ANSI Class 150 / JIS 10 K

Other nominal sizes on request.

## TUFLIN® Plug Port Arrangements Three Way Valves Type 771 / 0771 / 8771

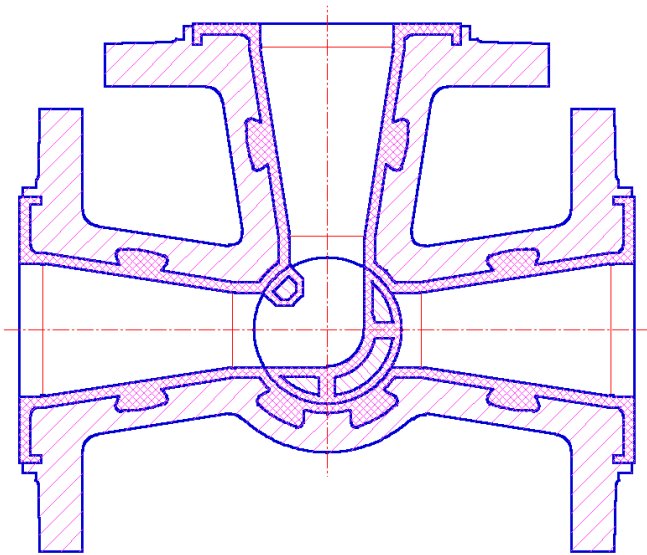

L-Plug

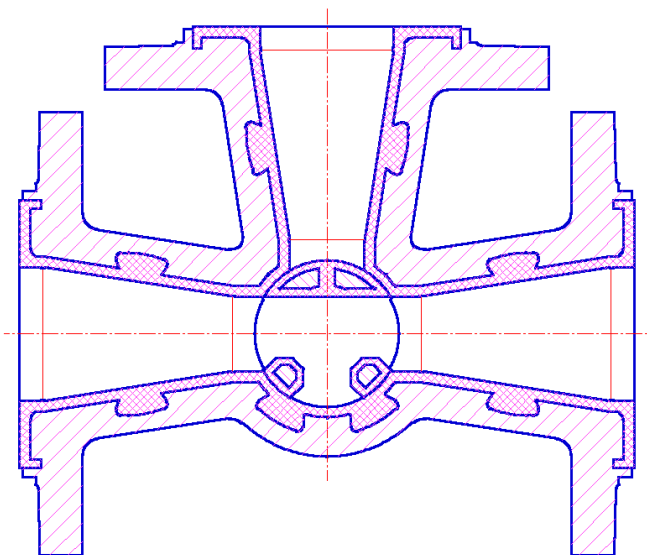

T-Plug

Please advise necessary port arrangement when ordering.

## TUFLIN® Fully Lined Flanged Four Way Valves

Type 141: DIN PN 10-16  
 Type 0141: ANSI Class 150  
 Type 8141: JIS 10 K

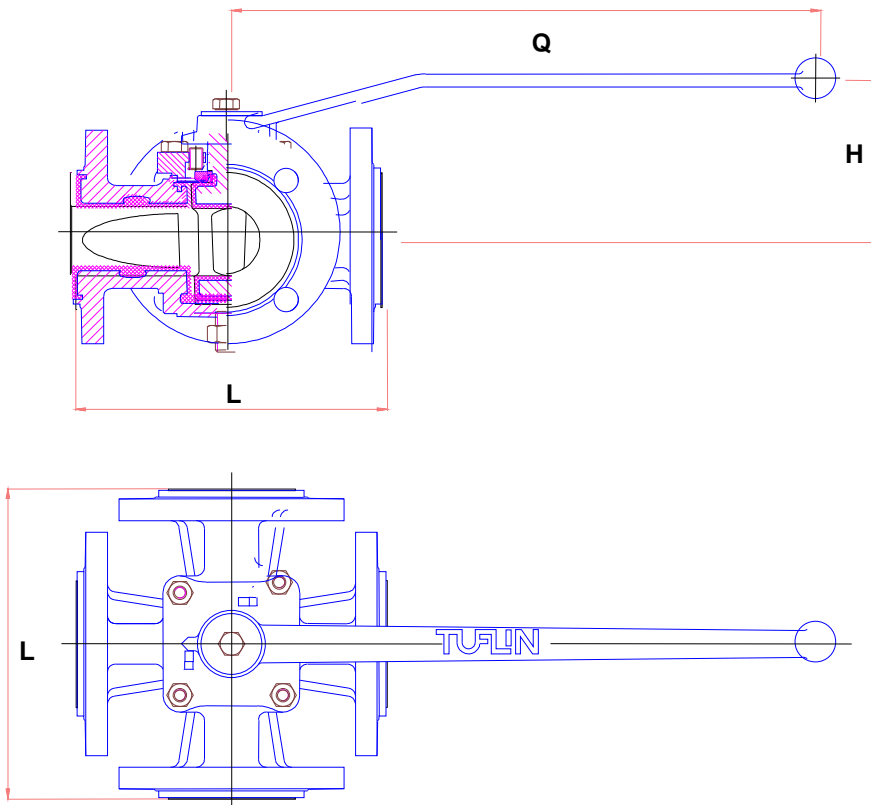

Wrench for DN 100 / NPS 4

### Dimensions with wrench in mm

DN	NPS	DN	L			Q	H	Approx. weight [kg]	Break-away torque [Nm]
			141	0141	8141				
25	1	25	160	160	160	96	260	7.6	65
40	1½	40	200	200	200	106	362	11.0	100
50	2	50	230	230	230	118	435	21.0	160
65	2½	65	290	290	290	118	435	27.0	160
80	3	80	310	310	310	132	435	33.0	210
100	4	100	350	350	350	149	600	48.0	300

\* DIN flanges drilled to ANSI Class 150 resp. JIS 10 K

**TUFLIN® Plug Port Arrangements - Four Way Valves**

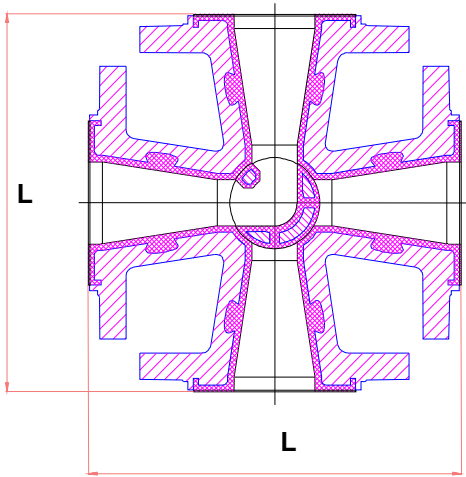

L-Plug

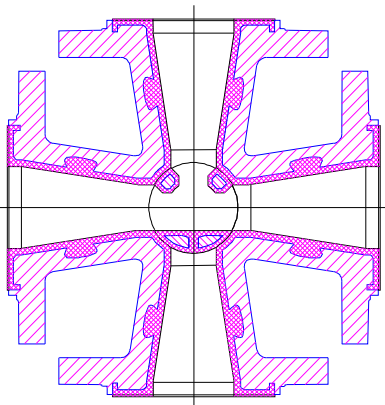

T-Plug

**Material**

Body:	A352-LCB
Body lining:	PFA
Plug:	Plug core steel (1.0570) PFA lining

Please advise required port arrangement when ordering.

Other materials upon request  
Subject to technical modifications.

## TUFLIN® Fully Lined Flanged Five Way Valve

Type 151: DIN PN 10-16  
 Type 0151: ANSI Class 150  
 Type 8151: JIS 10 K

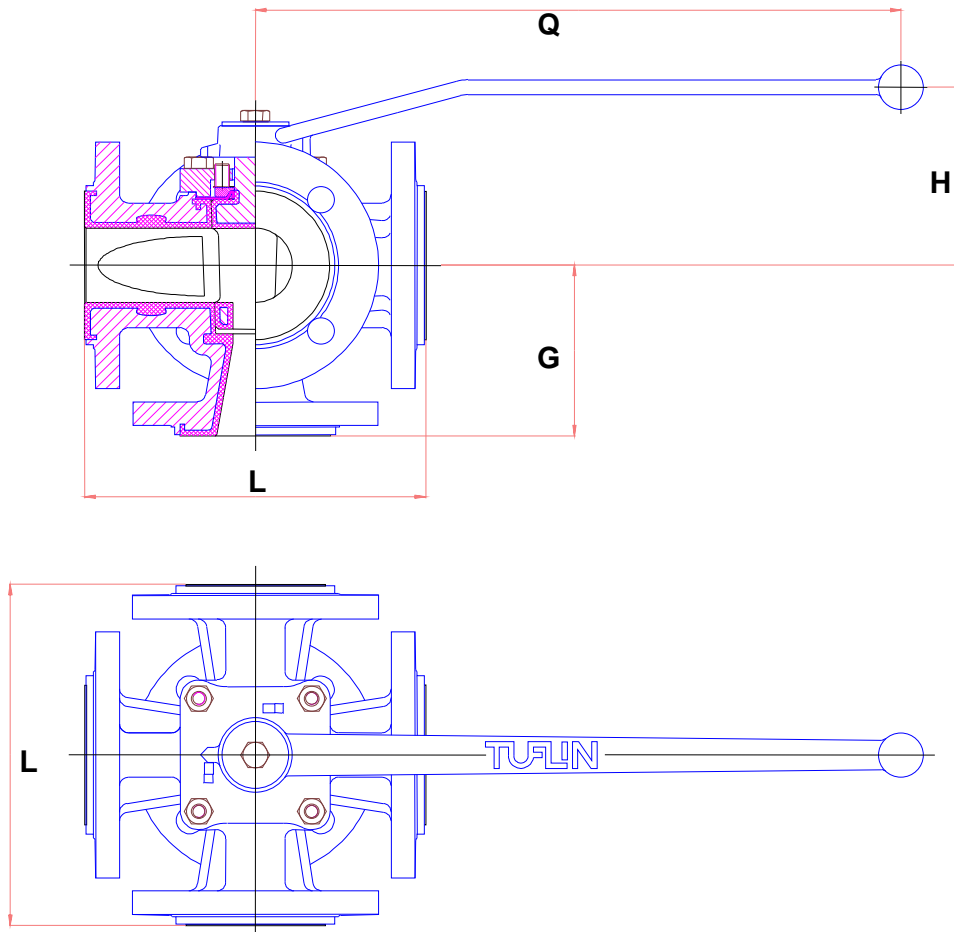

### Dimensions with wrench in mm

DN	NPS	DN	L			G	H	G	Approx. weight / kg	Break-away torque in Nm
25	1	25	160	160	160	80	96	260	7.8	65
40	1½	40	200	200	200	100	106	362	16.0	100
50	2	50	230	230	230	115	118	435	23.0	160
65	2½	65	290	290	290	145	118	435	30.0	160
80	3	80	310	310	310	155	132	435	34.3	210
100	4	100	350	350	350	175	149	600	50.0	300

\* DIN flanges drilled to ANSI Class 150 resp. JIS 10 K

## TUFLIN® Plug Port Arrangements Five Way Valves

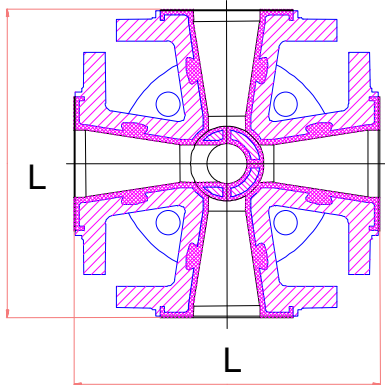

A-Plug

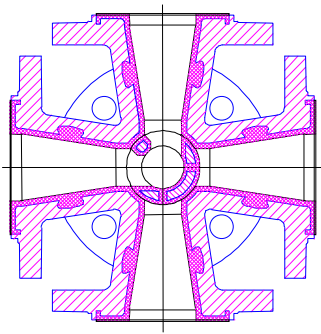

AX-Plug

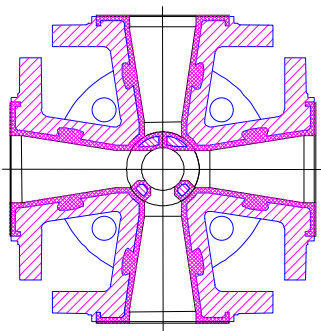

C-Plug

Please advise required port arrangement when ordering

### Material

Body: A352-LCB  
 Body lining: PFA  
 Plug: Plug core steel (1.0570)  
 PFA lining.

Other material, pressure classes and port arrangements upon request.  
 Subject to technical modifications.

## TUFLIN® Fully Lined Flanged Jacketed Plug, Type 121H

### Dimensions with wrench

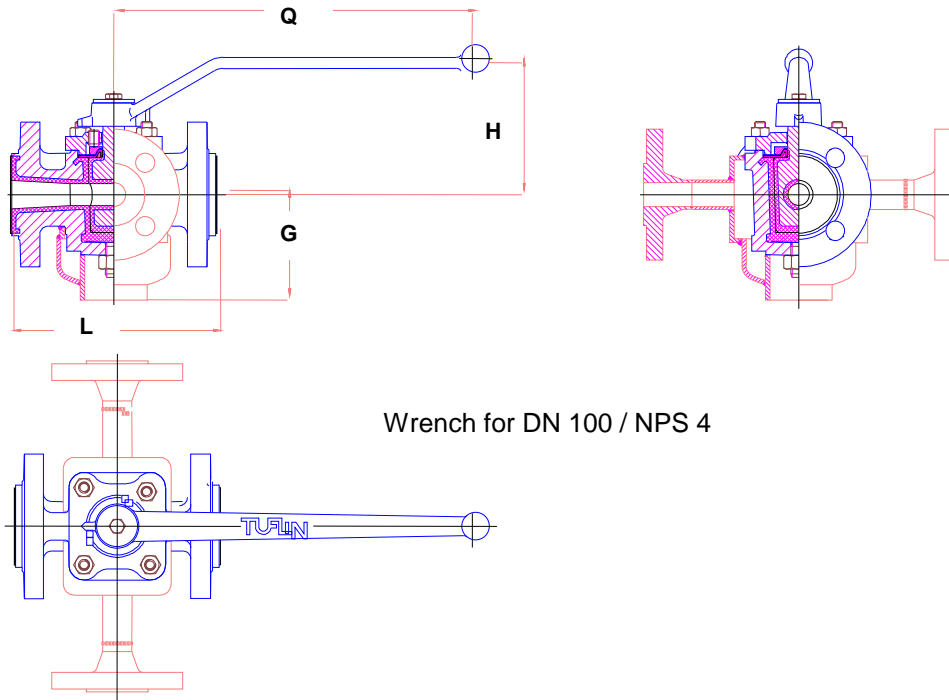

Wrench for DN 100 / NPS 4

### Dimensions with wrench in mm

DN	L	G	H	Q
25	160	80	96	260
40	200	90	106	362
50	230	110	118	435
65	290	110	118	435
80	310	120	132	435
100	350	145	149	600

Valve weights are subject to required jacket connection; further information on request.

Other nominal sizes and pressure classes on request

#### Materials:

Body: A352-LCB  
 Body lining: PFA  
 Plug: Plug core steel (1.0570)  
 Jackets: 1.0038

Other materials upon request



## TUFLIN® Fully Lined Flanged Jacketed Plug Valve

### Available Jacket-connections

Row 1: connection with Screw R ½

Row 2: connection with Socket NPS ½

Row 3: connection with flanges, flanges DN 15

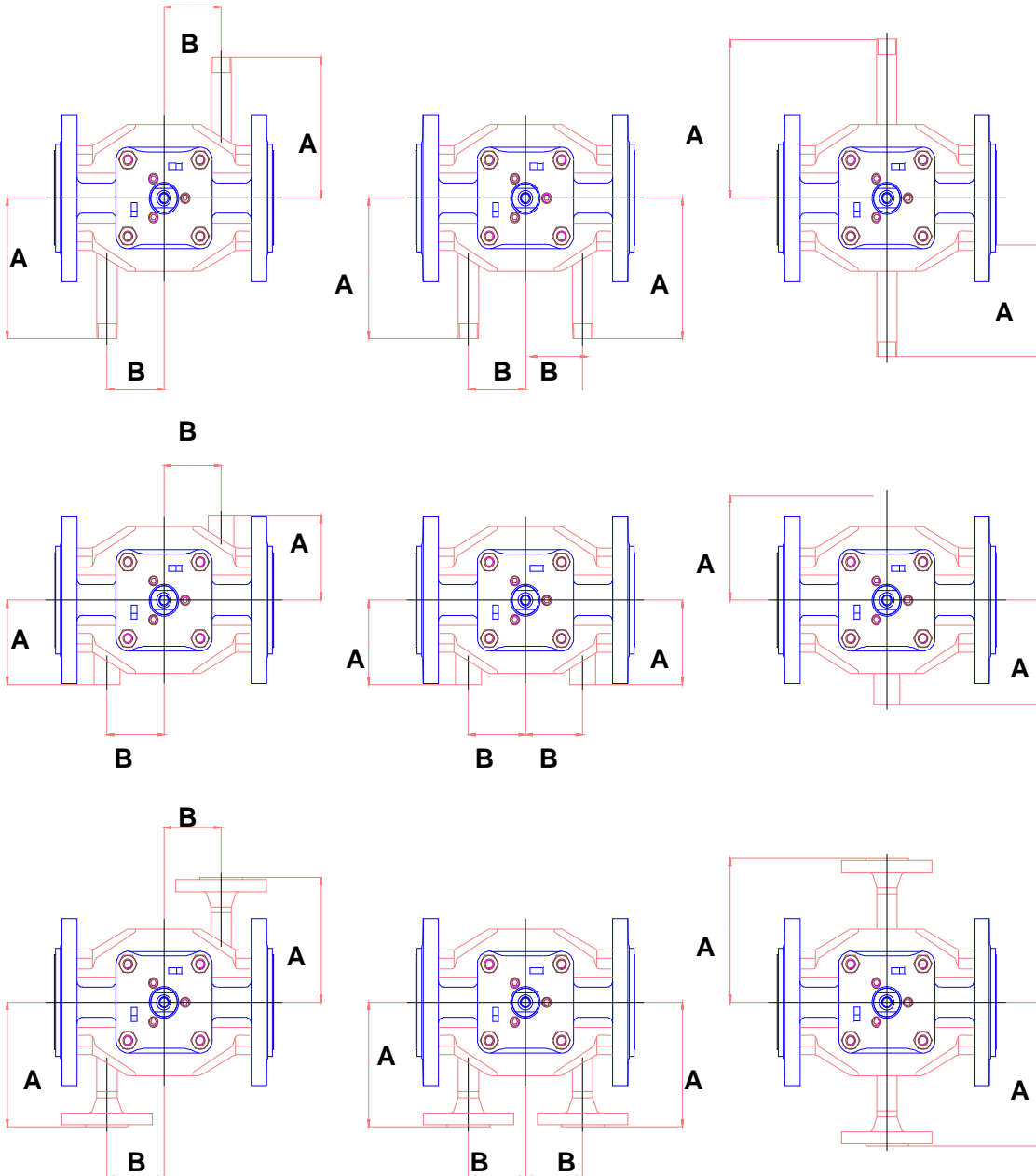

## TUFLIN® Fully Lined Flanged two Way Valves, Type 121H with Jacket

### Dimensions in mm

DN	PN	121 HA		121 HC		121 HN	
		A	B	A	B	A	B
15	10-16	-	-	-	-	135	-
20	10-16	-	-	-	-	135	-
25	10-16	119	35	119	35	135	-
40	10-16	134	50	134	50	145	-
50	10-16	140	60	140	60	158	-
65	10-16	140	60	140	60	158	-
80	10-16	159	65	159	65	159	-
100	10-16	174	80	174	80	174	-

### Dimensions in mm

DN	PN	121 HE		121 HG		121 HR	
		A	B	A	B	A	B
15	10-16	-	-	-	-	81	-
20	10-16	-	-	-	-	81	-
25	10-16	63	35	63	35	81	-
40	10-16	79	50	79	50	91	-
50	10-16	84	60	84	60	104	-
65	10-16	84	60	84	60	104	-
80	10-16	105	65	105	65	105	-
100	10-16	120	80	120	80	120	-

### Dimensions in mm

DN	PN	121 HJ		121 HL		121 HV	
		A	B	A	B	A	B
15	10-16	-	-	-	-	119	-
20	10-16	-	-	-	-	119	-
25	10-16	103	35	-	-	119	-
40	10-16	118	50	118	50	129	-
50	10-16	124	60	124	60	143	-
65	10-16	124	60	124	60	143	-
80	10-16	143	65	143	65	143	-
100	10-16	58	80	158	80	158	-

## TUFLIN® Fully Lined Flanged Two Way Valve, Type 121H with Jacket

### Dimensions in mm

NPS	DN	PN	021 HN	021 HR	021 HV
			80121 HN	80121HR	80121
			A	A	A
½	15	10-16	-	-	-
¾	20	10-16	-	-	-
1	25	10-16	135	81	119
1 ½	40	10-16	135	81	119
2	50	10-16	141	86	125
	65	10-16	-	-	-
3	80	10-16	80	150	133
4	100	10-16	160	105	143

Multi-port jacketed versions on request

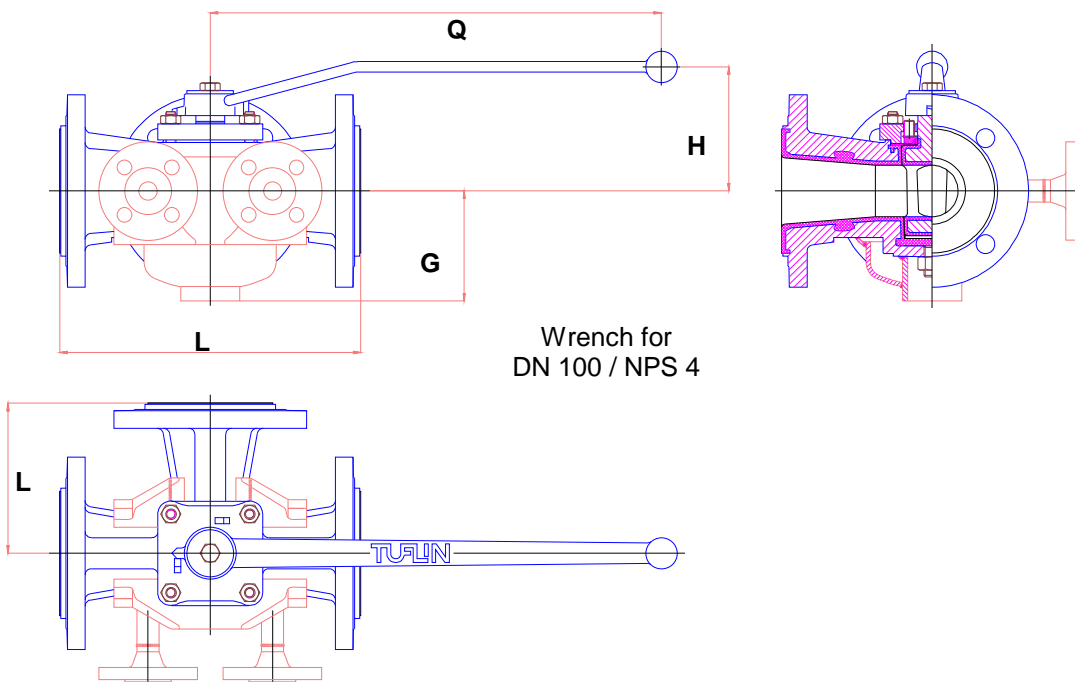

Dimensions and other details on request.

Subject to technical modifications

## Design and Dimensions of Wrenches for TUFLIN® Plug Valves (with flow direction indicator)

- Figure 1 Standard Wrench**  
Material: Aluminium
- Figure 2 Wrench with hub cap**  
Material: Steel  
(Special Design for DN 15 - 80 / NPS ½ - 3)
- Figure 3 T-Wrench**  
Material: Steel

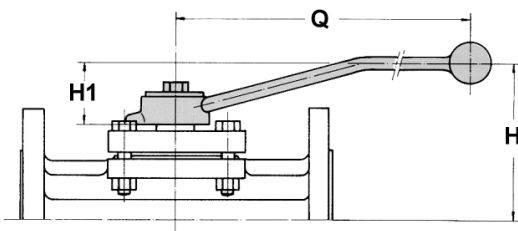

DN	NPS	H	H1	Q	Weight in kg
15	½	76	45	180	0.1
20	¾	76	45	180	0.1
25	1	96	46	260	0.2
32		96	46	260	0.2
40	1 ½	106	45	362	0.3
50	2	118	47	435	0.4
65		112	47	435	0.4
80	3	132	47	435	0.4

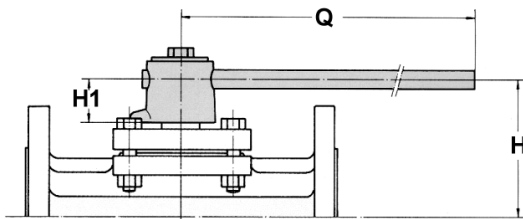

DN	NPS	H	H1	Q	Weight in kg
15	½	68	36	190	0.3
20	¾	68	36	190	0.3
25	1	80	30	250	0.7
32		80	30	250	0.7
40	1 ½	91	30	300	1.1
50	2	108	37	450	1.6
65		102	37	450	1.6
80	3	122	37	450	1.6
100	4	151	45	600	3.2

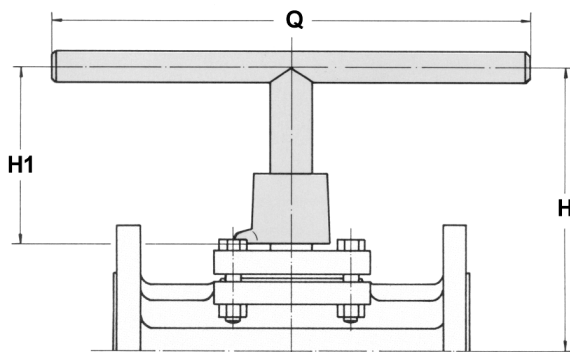

DN	NPS	H	H1	Q	Weight in kg
15	½	132	100	300	0.3
20	¾	132	100	300	0.3
25	1	195	145	300	0.6
32		195	145	300	0.6
40	1 ½	206	145	400	0.9
50	2	216	145	500	1.3
65		210	145	500	1.3
80	3	230	145	500	1.3
100	4	256	150	600	2.8

T-Wrench: Recommended wrench for isolated piping systems.

DN 150 – 250 / NPS 6 – 10 are standard equipped with a worm gear  
Subject to technical modifications



Teflon® is a registered Trademark of I. E. du Pont de Nemours and Company  
and is used under license by XOMOX International GmbH & Co.

**CRANE**

A Crane Co. Company